



Fitting Instructions

MA465

MAZDA BONGO FRIENDEE
(SGL3,SGL5,SGL11 & SGLW) 1992 ON

Bolt Kit

WA	2	6MM ROUND WASHERS
WB	2	8MM ROUND WASHERS
WC	3	10MM SMALL WASHERS
H	2	6x30 BOLTS
SW	4	10MM SQUARE WASHERS
C	2	8x30 BOLTS & GRIP WASHERS
F	2	16x50 BOLTS,NUTS & GRIP WASHERS
B	3	10 x 1.25 x 30 BOLTS & GRIP WASHERS
E	2	12x35 BOLTS,NUTS & GRIP WASHERS
G	2	12x35 BOLTS & GRIP WASHERS
D	3	10x90 BOLTS,NUTS & GRIP WASHERS
A	1	10x130 BOLTS,NUTS & GRIP WASHERS
BU	1	93 x 19MM BUSH
BS	3	54 x 16MM BUSHES

Contents

CB	1	CROSSBAR
LP	1	LEFT PLATE
RP	1	RIGHT PLATE
CP	1	CAPTIVE PLATE

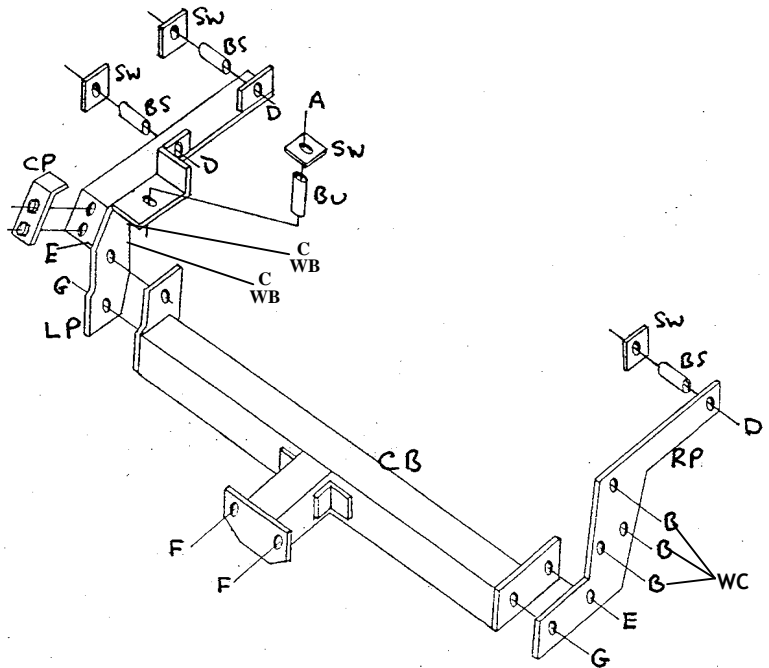

1. REMOVE CHROME UNDERUN BAR AND CAPTIVE PLATES FROM CHASSIS (WHERE FITTED) REMOVE TOWING EYE FROM RIGHT CHASSIS, LOWER EXHAUST AND REMOVE HEAT SHIELD. FROM INSIDE THE BOOT REMOVE THE REAR TRIM PANEL.
2. ON THE RIGHT SIDE LOOSELY ATTACH RIGHT PLATE RP TO EXISTING THREADED HOLES USING BOLTS B AND WASHERS WC. USING RIGHT PLATE RP AS A JIG DRILL FORWARD HOLE THROUGH CHASSIS 11mm. REMOVE PLATE RP AND OPEN UP THE OUTSIDE CHASSIS TO ACCEPT BUSH BS. REPLACE PLATE RP USING BOLTS B AND BOLT D WITH BUSH BS AND SQUARE WASHER SW..
3. ON THE LEFT SIDE TEMPORARY ATTACH PLATE LP TO THE CHASSIS USING BOLTS C AND WASHERS WB WITH CAPTIVE PLATE CP. USING PLATE LP AS A JIG DRILL THROUGH THE CHASSIS RAIL TWO 11mm. REMOVE PLATE LP AND OPEN THE INNER HOLES TO ACCEPT BUSHES BS. REPLACE PLATE LP AND SECURE USING BOLTS C WITH CAPTIVE PLATE CP AND BOLTS D WITH BUSHES BS AND SQUARE WASHERS SW.
4. DRILL UP THROUGH REAR CROSS BEAM 11mm AND OPEN UP THE HOLE TO ACCEPT BUSH BU .ATTACH USING BOLT A WITH BUSH BU AND SQUARE WASHER SW.
5. ATTACH CROSSBAR CB TO THE PLATES RP AND LP USING BOLTS E AND G.
6. CHECK AND TIGHTEN ALL BOLTS. REPLACE THE REAR TRIM PANEL AND HEAT SHIELD USING BOLTS H AND WASHERS WA.

PLEASE REFER TO YOUR VEHICLE HANDBOOK FOR THE MAXIMUM TOWING WEIGHT

All A1 towbars are finished using an anti-corrosive primer. To maximise the appearance of your towbar, and minimise corrosion, we recommend that you regularly inspect and repaint it, especially in exposed areas.

A1 Towing Limited, Parkway Link, Kettlebridge Road, Sheffield, S9 3AJ
T: 0800 404 7070 F: 0845 30 10 476 E: technicalsupport@a1-tow.com

www.a1-tow.com