

THE ZIG C.F.9 CARAVAN BATTERY CHARGING & DISTRIBUTION SYSTEM INSTRUCTIONS FOR USE & FITTING



IMPORTANT FEATURES

- Fully automatic electronic charging control
- Suitable for touring and motorised caravans
- Mains battery charging up to 12 amps depending on battery state
- Charging from vehicle or generator
- Mains voltage to 12 volt conversion – up to 4.5 amps continuous current
- Switched selection of source, car or auxiliary battery
- Double pole illuminated mains switch
- Safety – the C.F.9 incorporates no less than 8 protection devices to eliminate overheating and over current problems
- Facility for refrigerator (12 volt and mains supply)



ZIG ELECTRONICS
St MARY'S ROAD,
NUNEATON, WARWICKSHIRE,
CV115AU.
ENGLAND

INSTRUCTIONS FOR USE

Please read these instructions carefully before operating the electrical equipment in your caravan

1. The Caravan Battery

If the manufacturer, or your dealer, has not fitted a battery we recommend that one is fitted in order to get the best out of your Zig electrical system. Most manufacturers allocate a space for the battery and supply the necessary cable for connection. In this case, simply locate a new battery in the space provided and connect the wires to the battery: red to positive, black to negative. The 25 amp line fuse (supplied) should be connected in the positive lead. Note: that if blue and white wires are used, blue is positive, white is negative. It is important that a proper connection is made to the battery using terminals and screws. Crocodile clips must never be used as they deteriorate quickly and are a fire risk. A smear of petroleum jelly should be applied to the battery terminals. See No.4 in Important Notes regarding batteries.

If the manufacturer has not allocated a space for the battery, refer to 'Fitting the Battery' in Instructions for Fitting.

2. Using your 12 volt equipment

Turn on the '12 volt' switch and set the 'CAR/CARAVAN' switch to 'CARAVAN'. The battery condition indicator will light either red or green depending on the state of the battery and the 12 volt equipment in the caravan will be operative. This switch need only be turned off when the caravan is not in use. Note that the fridge is independently wired and is not controlled by this switch. If it is desired to use power from a car, set the 'CAR/CARAVAN' switch to 'CAR'. (*The car must of course be connected*).

3. Charging from the Mains

Ensure that a mains supply is available to your caravan through the external mains input socket and set the 'MAINS ON-OFF' to 'ON'. The 'CHARGER' switch should be set to the 'ON' position. Fully automatic electronic charging regulation is fitted to the C.F.9 – this means that it will only supply the current the battery needs when the caravan is in use.

N.B. Do not leave the charger switched on for long periods when the caravan is not in use.

4. Charging from the Vehicle

When the caravan is attached to the car and the 'CHARGER' switch is set to the 'TOWING' position, charging of the caravan battery will take place when the vehicle engine is running. The amount of charge depends on a number of factors – the state of charge of both batteries, the cable in use and the distance between the car and caravan batteries.

5. Selection of 12 volt Source

It is possible to choose the source of 12V current for the caravan from either the car or caravan battery. This facility will be found to be very useful when on sites without mains electricity as it will allow the car to run the caravan equipment when it is on site leaving the caravan battery well charged for periods when the car is moved. To use the car, simply connect the 7-pin plug and socket (either directly or through an extension lead) and set the 'CAR/CARAVAN' switch to 'CAR' – when the car is removed reset this switch to 'CARAVAN'.

IMPORTANT: To effect this operation, the right hand switch **MUST** be in the on-site position. It is important to remember that if the car is not driven for long periods and the switch is left in the 'CAR' position **THE CAR BATTERY WILL BE FLATTENED.**

N.B. Mains charging cannot be effected with the switch in the 'TOWING' position. Extra care should be taken with cars fitted with dynamos as these do not provide as much output as alternators.

6. The Battery Condition Monitor

The purpose of this device is to warn that the caravan battery is becoming discharged. The red light will glow when the battery voltage is below 11 volts, above this voltage the green light will glow. No harm will come to the system or the battery if the accessories are used when the red light is on and it will be found that possibly another few days reserve of current is available after the red light first appears. A true reading will only be given when all the 12 volt equipment is switched off and when neither charging system is in operation. The red light may come on when an appliance is switched on, this is normal – current surges cause momentary voltage drop. It is important to remember that the battery monitor is not a charging indicator. The fact that the green light is on does not mean that the battery is fully charged. Even with a flat battery the green light will glow if either charging system is operating due to the high terminal voltage present at the battery.

7. The Fuses

There are six fuses fitted to the C.F.9.

The mains fuses are in the smaller of six fuse holders on the front panel and are standard 20mm x 5mm glass quick-blow fuses. The fuse holders can only be removed with a screwdriver (this is to comply with electrical safety regulations).

The three 10 amp fuses mounted on the right of the panel protect the various accessories connected to the Zig system and are standard 1¼" glass quick-blow fuses. Access to the fuses is by turning the holder ¼ turn in the direction of the arrow on the front.

The 15 amp fuse controls the 12 volt fridge.

All the fuses are available worldwide from electrical and radio dealers. Under no circumstances should a fuse of a different type or value be fitted.

WARNING – In the event of a fuse blowing there exists a fault in the circuit protected by that fuse and the cause should be ascertained before replacing the fuse. It is important to remember that a fuse is fitted for the protection of the circuit and is a safeguard against fire and injury. Never remove the front panel with mains, battery or car connected. There are no user serviceable parts inside.

8. **Using the C.F.9 as a Converter**

When a mains supply is connected to the caravan the unit can be effectively used as a mains to 12 volt converter to power the 12 volt equipment in the caravan. It does this by replenishing the power drawn from the battery and will automatically adjust this power to the amount being drawn from the battery. Note that the unit will work without a battery installed in the caravan but we do not recommend this type of use. A battery provides the necessary smoothing required by the increasing number of electronic items being fitted to modern caravans – items such as strip lights, radio, television, water heaters, etc.

IMPORTANT NOTES

1. Owing to the powerful output available the unit will get quite hot during mains charging. An automatic thermal cut-out is fitted which will switch the unit off if for any reason it reaches too high a temperature. It is important, therefore, not to obstruct the front or rear of the case with clothing or similar items as this will cause the thermal cut-out to operate more frequently and will reduce the efficiency. Note that the thermal cut-out is completely automatic and will reset when conditions return to normal.
2. The 12 volt part of the fridge is connected to the car via the C.F.9. Note that if it is switched on when the engine is not running, there is a risk of flattening the battery.
3. The 'MAINS ON-OFF' switch lights up to show that the mains is connected to the caravan. It serves only to switch on and off the battery charger and the fridge. Never connect any other mains equipment to the C.F.9.

4. **Batteries**

Choice of battery will be dictated by the space available, the cost and the amount of use but it must be of the lead acid type, six cells and 12 volts. For most installations a battery of between 40 and 50 ampere/hour will suffice. Car batteries are designed to supply the very high current required to start an engine, this sort of use is never called for in a caravan and it is therefore not necessary to buy expensive multi-plate types for caravan use. One of the latest maintenance-free batteries designed for the purpose will give the best service. On average, a fully charged battery will last approximately one week with careful use, three to four weeks with help from the car as explained in the section 'Selection of the 12 volt Source'. Under no circumstances use a battery which has been scrapped for car use due to faulty cells, etc – always purchase a new battery which will give years of service.

5. In order to obtain satisfactory charging from your car, it is essential that the car is properly wired with suitable cable. Refer to the section in the installation instructions headed 'Wiring the Car'.
6. Maintenance is not required other than to keep the front panel clean with a dry cloth. It is, however, important to make a check from time to time on the condition of wiring in the caravan – in particular, the 7-pin plugs and sockets and the mains input connection.

Current Usage

The biggest consumer of current in a caravan is usually the lights – these are highly efficient in modern vans but they are used for longer periods than most other appliances. Take care that lights are not left on when not in use.

Water pumps use quite heavy currents but as they are only used intermittently the total consumption is quite small.

Monochrome televisions use quite small currents but do remember to turn off after watching a programme. Colour televisions should only be used when mains is available as the consumption will flatten a 40 a/h battery in about four hours.

Take care when fitting extras to your van, they may use very small currents themselves but a number of items left on for two weeks continuously could use all your available battery supply.

Lamps which use incandescent bulbs (car type) such as spotlights, etc. are very much less efficient than strip lights and should only be used for short periods.

Note that these will accept an 18w or 21w car bulb instead of the original 10w supplied. Two 21w bulbs will drain your battery in about eight to 10 hours.

If you use the type of shaver inverter with switched contacts, never leave your shaver lead plugged in.

Mains Electricity

The Zig Charging and Distribution unit is designed to run on 200 to 240 volt AC mains electricity. ***Never connect to a DC supply.***

In remote parts of Europe and the whole of the USA the supply is 110 volt AC. The unit will not charge from the mains with this supply, although no harm will be done if it is connected to 110 volt. The 12 volt equipment will of course work normally including charging from the car. Note that where the supply is low, i.e. 200 volts, efficiency in mains charging will be reduced.

The C.F.9 has been specially designed to operate safely on mains electricity in a caravan. It is protected by a double pole mains switch, double wound mains transformer and fuses. It will remain safe even if the polarity of the mains is reversed. ***This does not apply to other mains equipment in the caravan.*** If you wish to fit extra mains appliances in the caravan, you should consult a qualified electrician and the use of an Earth Leakage Circuit Breaker is strongly recommended. Remember mains voltage can be fatal.

FAULT FINDING CHART

| SYMPTOM | REMEDY |
|---|--|
| 12 volt appliances work but battery not charging from mains. | Check centre switch is in MAINS position. Check mains fuses and mains supply to caravan. If thermal cut out has operated allow time for this to reset. |
| 12 volt appliances work from caravan battery only. Battery not charging from car. | Check car wiring, especially 7-pin plug and socket. Check car line fuse. N.B. If a split charger has been fitted to the car, power will only be available when the engine is running. |
| None of the 12 volt appliances work. | Check battery line fuse. Check 12 volt switch is ON. |
| 12 volt appliances work only when mains connected. | Check battery line fuse or battery connections. |
| Poor television picture and dim lights. | Battery nearly flat. Charge battery. |
| Battery monitor red light flickers when water pump operated. | Normal, due to voltage drop caused by motor surge. |
| Unit gets hot for long periods and thermal trip can be heard operating. | Faulty battery or excess current being drawn by appliances. Turn off some equipment until battery is charged. If this persists, check battery for faulty cell. |
| Persistent blowing of one of 10 amp fuses. | Check the appliances supplied by this fuse. To isolate these, switch on all equipment, remove fuse and note which equipment stops working. |
| Battery line fuse blows when battery connections made. | Battery connected wrong way round. |
| Radio interference when mains charging. | Check battery line fuse. Interference may occur if battery is very low, but will cease when it is fully charged. |

INSTRUCTIONS FOR FITTING

INTRODUCTION

Please read these instructions before starting installation work.

Choose a suitable position for the C.F.9 unit bearing in mind the following:

1. The minimum size of the compartment for the unit must be 190mm deep, 330mm wide and 130mm high. This will give the minimum clearance all round which must be allowed, i.e. 25mm with extra at the rear for the fridge connector.
2. Air should be allowed to circulate freely over the back of the unit. Ventilation to the compartment, in the form of two 25mm holes top and bottom, parallel to the front panel and centrally over the unit.
3. Access to the mains inlet socket will be required so the position of the C.F.9 and this socket should be chosen at the same time.
4. Access will be needed to the caravan battery and to the wiring for the electrical accessories.
5. **WARNING: THIS APPLIANCE MUST BE EARTHED.**

The side of a wardrobe or cupboard is usually a satisfactory mounting point provided there is access to the terminal strip and the refrigerator socket on the back of the C.F.9 unit.

Cut a rectangular hole 280mm (11") by 83mm (3¼") at the mounting point. If the panel is very thin fix batons to the back of the top and bottom edges of the hole and secure the unit with the screws provided. Gluing the batons in place will make removal of the unit easier should this be necessary.

WIRING

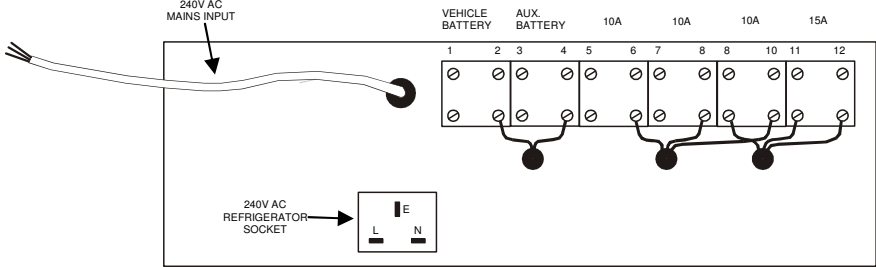

Figure 1 – Terminal connections

WARNING: UNDER NO CIRCUMSTANCES USE CABLE SMALLER THAN THAT RECOMMENDED

Suitable cable can be bought from most motor accessory shops. Care should be taken when wiring the unit and if there is any doubt a qualified electrician should be consulted.

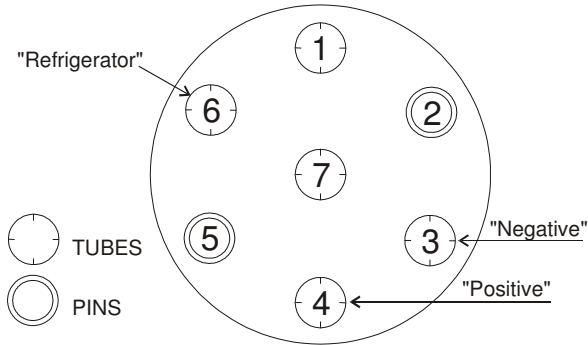

Figure 2 - 12S plug

1. Disconnect the 12S plug and socket between the car and the caravan.
2. Using cable of at least 2mm² (28/03):
 - (a) Connect negative terminal (-) 1 on the C.F.9 unit to negative terminal 3 on the 12S plug.
 - (b) Connect positive terminal (+) 2 on the C.F.9 unit to positive terminal 4 on the 12S plug.

Do not connect your car at this stage.

If you are wiring a motorised caravan, connect No.1 to earth and No.2 to the main battery. The starter solenoid provides a convenient connection in some cases.

A 25amp line fuse must be fitted in the positive line (No.2 on C.F.9) as near to the main battery as possible.

At this stage a suitable position for the auxiliary battery should be chosen. The position **MUST BE VENTILATED TO THE OUTSIDE**. The battery should be mounted so that it cannot tip over and the surface beneath it should be protected from corrosion due to accidental spillage. Connect the battery using 2mm² (28/03) cable to the C.F.9 fitting the in-line 25amp fuse supplied in the positive cable as near as possible to the battery.

Battery positive (via fuse) to No.4 terminal block on C.F.9.

Battery negative to No.3 terminal on C.F.9.

NEVER use crocodile clips to connect the battery as these deteriorate quickly and are a fire risk. **AVOID FLAMES AND SPARKS NEAR THE BATTERY.**

Always use proper terminals and screws and smear the connections with petroleum jelly.

Before making any further connections, temporarily remove the in-line fuse from its holder and for motorised caravans remove the other in-line fuse as well.

The various accessories can now be connected to the C.F.9 sharing the load as equally as possible. The outlets are wired to Nos. 6, 8 and 10 (all positive) and the corresponding negative connections are Nos. 5, 7 and 9. As all the negative connections are joined to each other it does not matter which one is used for each fused outlet.

The following system is suggested (Figure 3 overleaf):

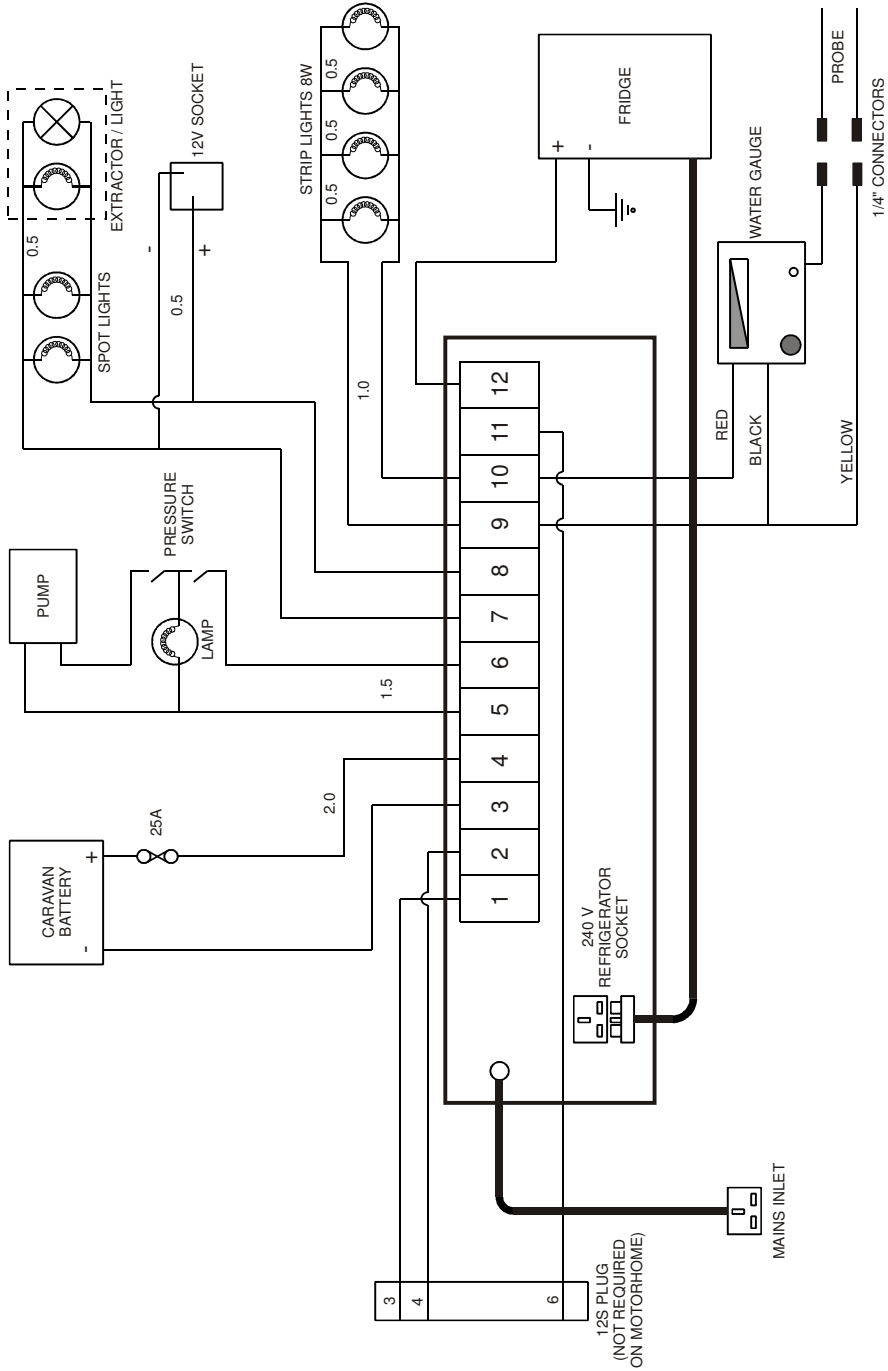

Figure 3. Suggested Wiring Diagram for the C.F.9

Water Pump to Nos. 5 and 6
Fan, Cooker Hood etc to Nos. 7 and 8
Lighting to Nos. 9 and 10

**UNDER NO CIRCUMSTANCES MUST A REFRIGERATOR BE CONNECTED TO
POSITIVE TERMINALS 2 -10**

Connecting the Refrigerator

Owing to the high current drawn by a refrigerator it should be wired to the main battery in such a way that it will operate only when the vehicle engine is running. The Zig RM12 relay, which comes with fitting instructions, will ensure that the main battery is not used for the refrigerator unless the engine is switched on.

The Zig C.F.9 unit is provided with two circuits for electricity supply to a caravan refrigerator – one for 12 volts DC and the other for AC mains voltage.

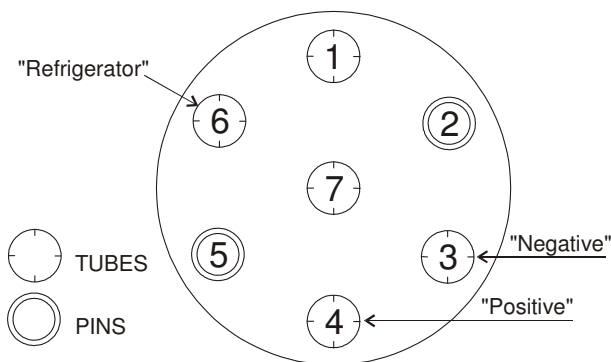

Figure 4 – 12S plug

12 Volts DC

Connect terminal No.11 on C.F.9 unit to terminal 6 (red cable) on the 12S plug (Figure 4). Connect the 12 volt positive wire from the refrigerator to terminal 12 on the C.F.9 unit.

These two terminals are a convenient method for connecting the refrigerator and provide protection for it through the 15 amp fuse on the front panel of the unit. They are not otherwise part of the unit's circuitry and should not be used for connecting other appliances.

Connect the negative wire from the refrigerator to negative earth, preferably to the 12S plug termination (No.3). In motorised caravans go direct to the chassis at the nearest available point.

THE MAINS WIRING

WARNING: Mains electricity is dangerous, particularly in caravans. If you do not have the necessary electrical knowledge you should entrust this part of the installation to a qualified electrician. The connection to the mains supply must be done in accordance with the I.E.E. Wiring Regulations for caravans.

Although not required by legislation at the time of going to press you are strongly recommended to fit a R.C.C.B. (Residual Current Circuit Breaker), also known as an Earth Leakage Circuit Breaker. These are an inexpensive way of preventing electric shock. If such a device is fitted it must be of the current operated type, the specification is: 25 amp, 30 milliamp operating in approximately 30 milliseconds.

A compatible plug for the refrigerator is supplied with the unit. Connect the plug to the refrigerator cable as follows:

| | | |
|-----------------------|-----------|--------------------------------|
| BROWN | to | LIVE (marked 'L') |
| BLUE | to | NEUTRAL (marked 'N') |
| GREEN / YELLOW | to | EARTH (marked 'E' or ⚡) |

WARNING: *This appliance must be earthed.*

If the cable supplied with your refrigerator does not correspond with these colours you must consult a qualified electrician before connecting it. The 3-pin socket is protected by the 3 amp fuse on the front panel of the unit. NOTE: this 3-amp fuse is the master fuse for the whole unit and in the event of its failure due to a refrigerator fault the charger will not function until the fuse is replaced.

CAUTION: The three pin mains outlet on the unit is designed for use only with a caravan refrigerator and is not suitable for any other purpose. It MUST NOT be used for supplying 13 amp sockets or any other mains appliances.

When all the 12 volt connections are complete the mains connections can be made. The mains input plug and socket must be of the polarised type, i.e. connection can only be made one way round. Suitable sockets can be obtained from caravan accessory shops and chandlers. They should be to BS4343. Fit the socket to the side of the van in a suitable position. If an R.C.C.B is fitted, this should be as close to the socket as possible and the connections made with a 2.5mm flexible cable not exceeding 2 metres in length.

The input cable for the C.F.9 can now be connected, preferably using a small junction box (covered type) as follows:

| | | |
|-----------------------|-----------|---|
| BROWN | to | LIVE (Marked 'L' or coloured red) |
| BLUE | to | NEUTRAL (marked 'N' or coloured black) |
| GREEN / YELLOW | to | EARTH (marked 'E', or ⚡ or coloured green) |

INPUT 200 to 240 VOLTS AC 50/60Hz

WARNING: *This appliance must be earthed.*

NB: We recommend that this appliance is permanently installed in the caravan, i.e. 'built in'. We do not recommend the use of plug and socket connections for the installation.

If a 13 amp plug is used this must be connected as follows:

| | | |
|-----------------------|-----------|----------------|
| BROWN | to | LIVE |
| BLUE | to | NEUTRAL |
| GREEN / YELLOW | to | EARTH |

As the colours of the wires in the mains lead of this appliance may not correspond with the coloured markings identifying the terminals in your plug, proceed as follows:

The wire that is coloured green and yellow must be connected to the terminal in the plug which is marked with the letter 'E' or by the earth symbol, or coloured green or green and yellow.

The wire which is coloured blue must be connected to the terminal which is marked with the letter 'N' or coloured black.

The wire which is coloured brown must be connected to the terminal which is marked with the letter 'L' or coloured red.

Do not connect the mains supply to the caravan yet.

Check all the wiring carefully, looking particularly for stray strands which may short to earth. Protect the mains cable from damage by securing with cable clips.

Replace the auxiliary battery 25amp line fuse and referring to 'INSTRUCTIONS FOR USE' check that all the 12 volt accessories function correctly.

For motorised caravans replace the other 25 amp line fuse and check that current is available with the 'TOWING/ON SITE' switch in the 'TOWING' position.

In the case of touring caravans it is important to ensure that your car is properly wired before connecting to the van. If your car has previously been wired for touring, check carefully that it has been done in accordance with the following instructions. Alternatively, proceed to wire the vehicle as follows overleaf.

WIRING THE CAR

You are strongly recommended to fit the new 12S supplementary plug and socket to your car. For a number of reasons the 12N original socket is now fully utilised for road lighting if fog lights are used, also the cable used with the 12S system is of a larger diameter and better suited to the large current demands of modern caravans. Connections are made as in Figure 4.

The cable used must have a minimum dimension of 2mm² (28/03). The connection to terminal 4 on the 12S must be taken right back to the vehicle battery and a 25amp line fuse must be fitted in this line as near to the car battery as possible. Remember that any cable between the battery and the fuse is unprotected and is a fire risk. This fuse is fitted to protect your car and passengers as well as the caravan and must NOT be omitted. Connection to terminal 3 on the 12S should be made directly to earthed metal at the rear of the car. If you are fitting a cable for a refrigerator this goes to terminal 6 on the 12S, noting that a separate cable must be run back to the battery again with a 25amp line fuse. Do not attempt to join terminal 6 to terminal 4 as this will severely limit the charging current available and could result in the fridge flattening the caravan battery.

When the car wiring is complete, the caravan can be connected and the Zig system checked out as described in the 'INSTRUCTIONS FOR USE'.

Using the Mains Supply to the Caravan

The mains supply should be obtained from a domestic supply of 200 to 240 volt AC from a fused connection point. Caravan site supplies use the BS4343 outlet and suitable couplers can be obtained from most caravan accessory shops.

The cable used to connect the mains should be 3 core sheathed flexible mains cable not less than 2.5mm² and should be regularly inspected for damage. When the mains is connected switch on the 'MAINS ON-OFF' control on the C.F.9 and check that this lights up. Set the 'TOWING-ON-SITE' switch to 'ON-SITE' and temporarily disconnect the batteries (by removing the fuses) to check that the 12 volt equipment is working correctly. Reconnect the two batteries. Installation is now complete.

Split Chargers

With modern batteries split chargers are not necessary as batteries are now much more tolerant to equalisation. The relay type of split charger causes the major problem that current is only available from the vehicle battery when the ignition switch is on, thereby preventing use of the vehicle battery to assist the life of the caravan battery. The diode type of split charger causes voltage drop, this limits the charging current making it necessary to remove the battery for charging if mains is not available. If your car is already fitted with a split charger, we recommend that you remove or bypass it. If you disconnect a split charging relay ensure that a 25amp line fuse is fitted next to the car battery as described in '**Wiring the Car**'.

WARNING: If the battery is discharged the load drawn by the accessories in use must not exceed the rated output of the charging system, i.e. 4.5amps. If this is done thermal cut-outs in the unit will operate to switch off the supply to prevent overheating.

GUARANTEE

Zig products are fully guaranteed for a period of one year from the date of first purchase against faulty workmanship or materials.

Zig Electronics will repair any such items free of charge provided they have been installed and used in accordance with our instructions.

In the event of a fault the product should be returned to the place of purchase for repair or replacement under the terms of this guarantee.

This guarantee does not in any way affect your statutory rights under the Sale of Goods Act 1979.

WARNING: This document is copyright, it may not be reproduced in any form, copied or in any way retrieved for any purpose whatsoever except with the written consent of the publishers. The manufacturers reserve the right to alter this publication at any time.

COPYRIGHT: Zig Electronics 1994



**ZIG ELECTRONICS
St MARY'S ROAD,
NUNEATON, WARWICKSHIRE,
CV11 5AU
ENGLAND**